

# TD-017 :: Vinyl 7" Label with Small and Large Centre Hole

## KEYLINE

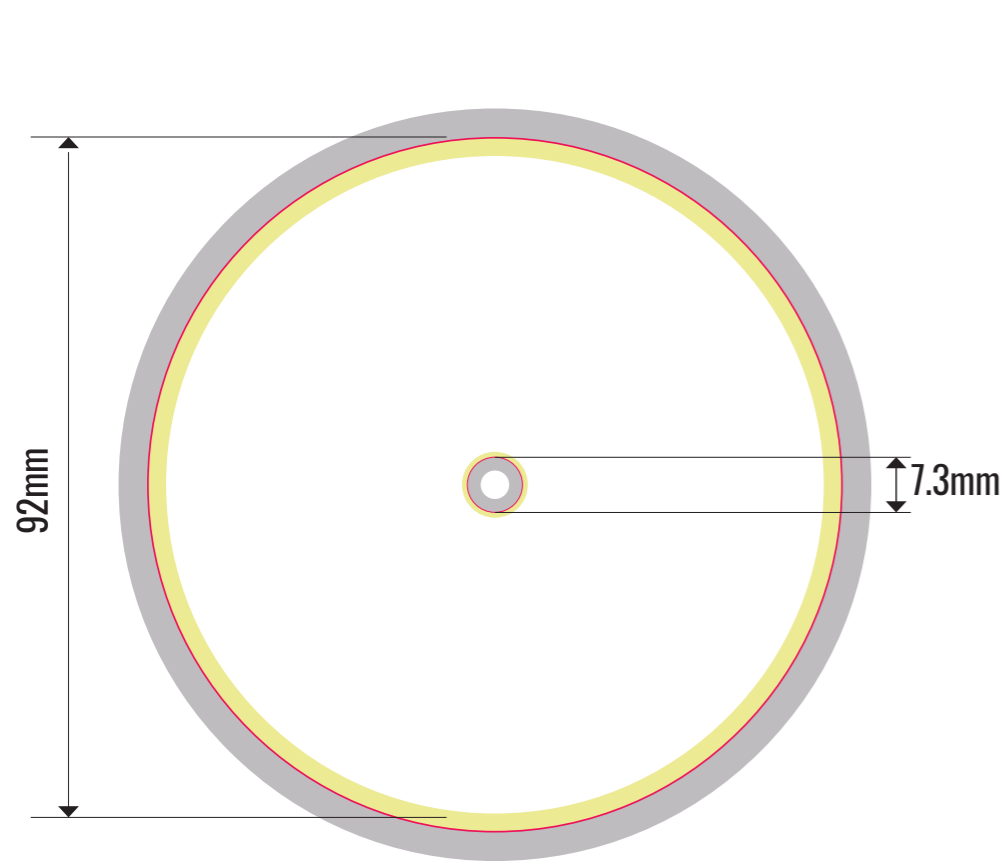

Small Centre Hole

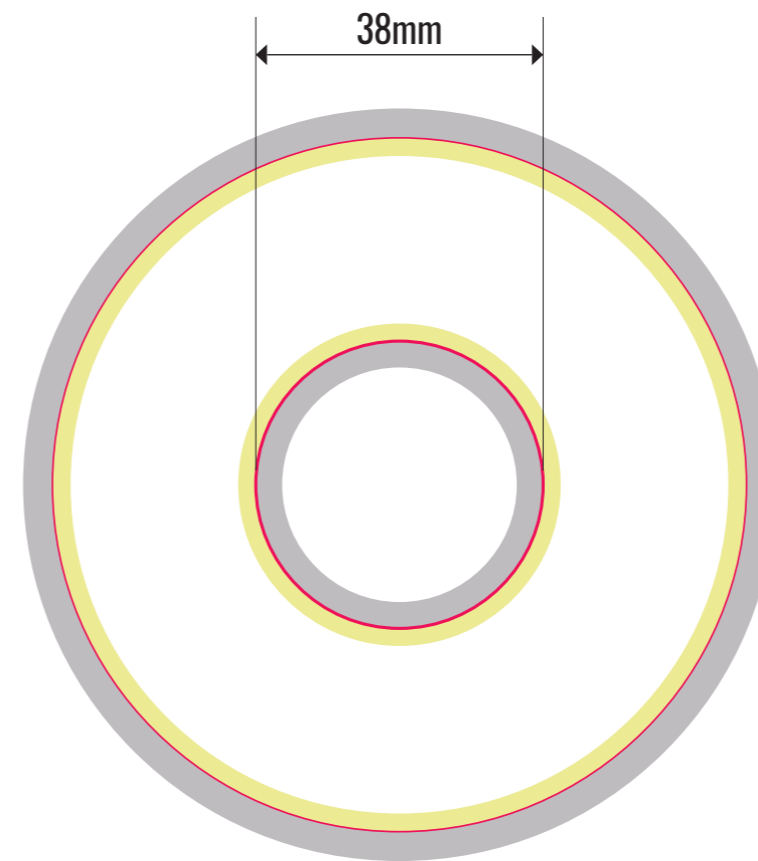

Large Centre Hole  
(Jukebox Style)

## FORMAT

Flat: 92mm diameter

## ARTWORK FORMATS

- Quark Express 8 or lower
- Indesign CC or lower
- Illustrator CC or lower
- Photoshop CC or lower
- PDF



## ARTWORK TIPS & GUIDANCE

### CMYK or Spot colours

All artwork must be set to CMYK and if you are using spot or Pantone™ colours make sure you define these as separate colour channels.

Whilst RGB colours can be converted to CMYK before printing, this can produce unpredictable results and colour matching cannot be guaranteed.

### Keep artwork clear from edges

We have indicated a safe area, which you should observe when laying out your artwork.

### Provide 3mm bleed, where shown

Having bleed ensures that your artwork goes all the way to the edge of the material, rather than plain material showing through after cutting.

### Check the resolution

All images must be 300dpi or higher. When line art is used, vector based images are generally good to go. Images with lower resolution may result in blocky or pixelated print.

### Fonts embedded or outlined

The most common issue encountered in printing is font substitution. This happens when fonts are used in a document that are not present on the pre-pres system.

To avoid any font issues either embed the fonts in your artwork file, or if the application allows it, convert all text to outlines.

### Total Ink levels

Caution is advised when CMYK is converted from RGB or when colours are made up of high percentage ink levels.

To avoid over-inking, which results in poor quality print and smudged appearance due to increased drying time, total ink levels shouldn't exceed 280% for all 4 channels.

### Overprint & Transparency Settings

Items set to overprint or relying on transparency settings display on screen but disappear or overlap when printed. Check your overprint settings, flatten your artwork and adjust or switch off overprint if necessary.

### Correct Pagination

If your artwork is for print parts with multiple pages, you should observe our pagination guides to make sure your pages run in sequence when printed.